

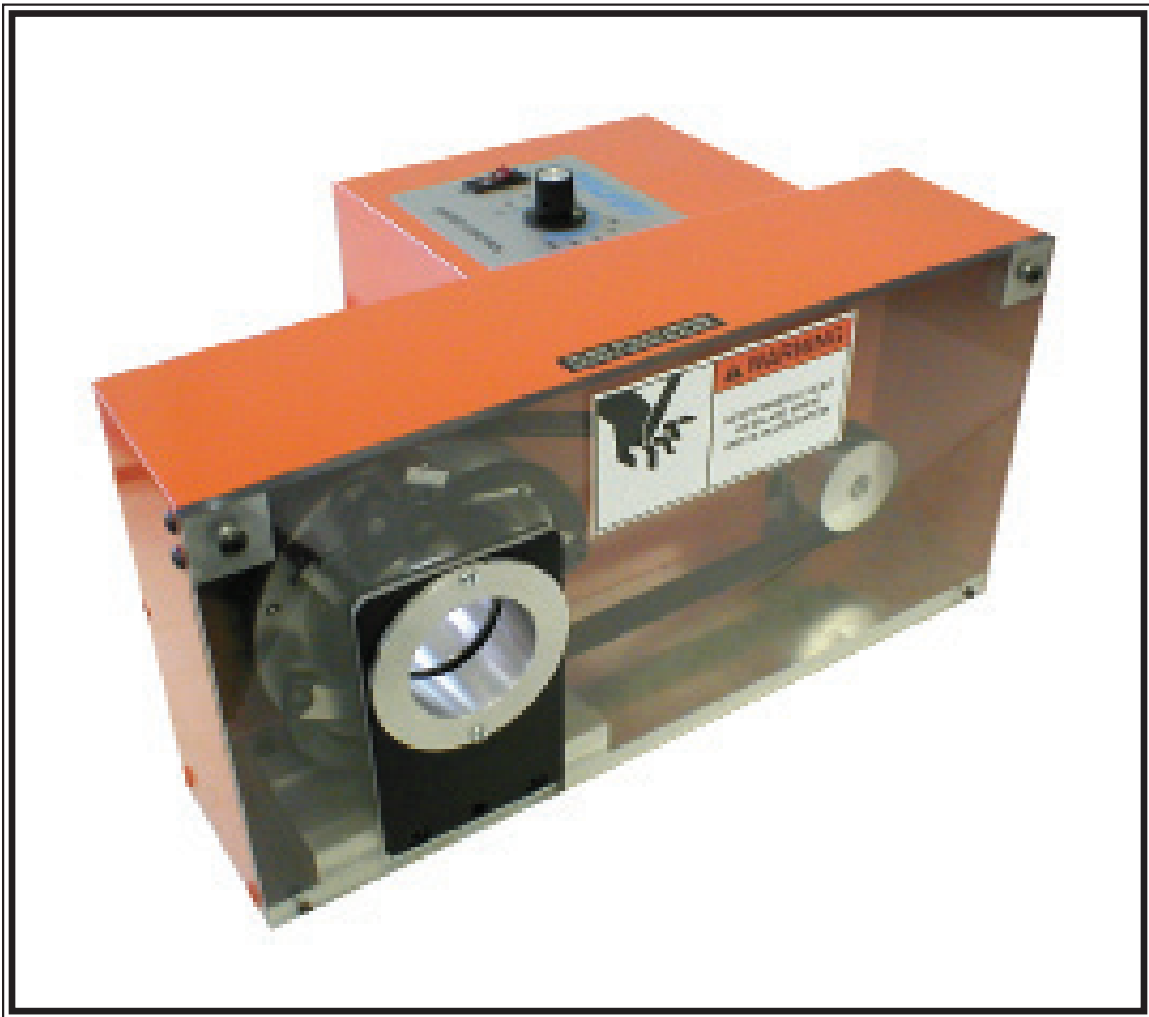

Operating Manual

Please Read Before Operating Unit



MODEL LFTC1 LARGE FLEXIBLE TUBE CUTTER

Service and All Spare Parts Available

The Eraser Company, Inc.
PO Box 4961
Syracuse, NY 13221, USA

Phone: (315) 454-3237
Fax: (315) 454-3090
Website: www.eraser.com
E-mail: info@eraser.com

LFTC1 LARGE FLEXIBLE TUBE CUTTER

IMPORTANT SAFETY INSTRUCTIONS READ ALL INSTRUCTIONS

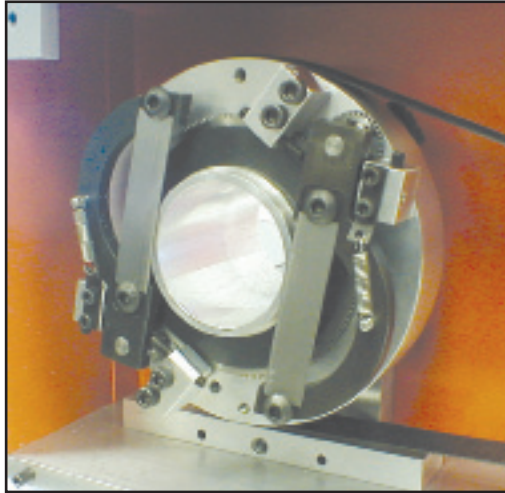

! WARNING

DO NOT OPERATE TOOL UNTIL YOU HAVE READ THOROUGHLY, AND UNDERSTAND COMPLETELY, ALL INSTRUCTIONS, RULES, ETC. ON THIS PAGE, AND IN THE OPERATING MANUAL. WHEN USING ELECTRIC TOOLS, BASIC SAFETY PRECAUTIONS SHOULD ALWAYS BE FOLLOWED TO REDUCE RISK OF FIRE, ELECTRIC SHOCK, AND PERSONAL INJURY, INCLUDING THE FOLLOWING:

GROUNDING INSTRUCTIONS

In the event of a malfunction or breakdown, grounding provides a path of least resistance for electric current to reduce the risk of electric shock. This tool is equipped with an electric cord having an equipment-grounding conductor and a grounding plug. The plug must be plugged into a matching outlet that is properly installed and grounded in accordance with all local codes and ordinances.

Do not modify the plug provided – if it will not fit the outlet, have the proper outlet installed by a qualified electrician.

Improper connection of the equipment-grounding conductor can result in a risk of electric shock. The green conductor with or without yellow stripes is the equipment-grounding conductor. If repair or replacement of the electric cord or plug is necessary, do not connect the equipment-grounding conductor to a live terminal.

Check with a qualified electrician or service personnel if the grounding instructions are not completely understood, or if in doubt as to whether the tool is properly grounded.

Use only 3-wire extension cords that have 3-prong grounding plugs and 3-pole receptacles that accept the tool's plug. Repair or replace damaged or worn cord immediately.

SPECIFICATIONS

Maximum Cut Length	Unlimited
Minimum Cut Length	2.00" (50.8mm)
Material Size.....	.50" – 2.00" OD (12.7mm – 50.8mm) flexible
Blades.....	Razor Type Double Beveled Steel Blade
Bushings.....	Bushings Purchased Separately Customer material sample is required to size bushings
Power	120V 60Hz or 230V 50Hz
Decibel Rating	60 db(A)
Size.....	14.5"W x 11.5"D x 7.5"H (368mm x 292mm x 190mm)
Weight	24 lbs. (11 Kg) 115V 26 lbs. (12 Kg) 230V

ORDERING INFORMATION

AR1431 (LFTC1).....	Manual Feed Large Tubing Cutter 120V 60HZ, Flexible Tubing Head
IR1819.....	Replacement Blade (2 required per machine)
IR1817..	Set of Custom Bushings for Flexible Tubing
PR1026.....	Replacement Flat Belt
IR1822	Operating Manual

Optional Parts

TR0176.....	Length Stop Rod 12"
-------------	---------------------

MODEL LFTC1 FLEXIBLE TUBE CUTTER

GENERAL INSTRUCTIONS

REMOVE ADJUSTING KEYS AND WRENCHES.

Verify that keys and adjusting wrenches are removed from tool before turning on.

KEEP WORK AREA CLEAN. Cluttered areas and benches invite accidents.

DON'T USE IN DANGEROUS ENVIRONMENTS.

Don't use power tools in damp or wet locations, or expose them to rain. Keep work area well lighted.

ALWAYS USE SAFETY GLASSES. Everyday eyeglasses only have impact resistant lenses; they are NOT safety glasses. Also use face or dust mask if cutting operation is dusty.

WEAR PROPER APPAREL. Do not wear loose clothing, gloves, neckties, rings, bracelets, or other jewelry that might get caught in moving parts. Nonslip footwear is recommended. Wear protective hair covering to contain long hair.

DON'T OVERREACH. Keep proper footing and balance at all times.

MAINTAIN TOOLS WITH CARE. Keep tools sharp and clean for best performance and to reduce the risk of injury. Follow instructions for lubricating and changing accessories.

DISCONNECT TOOL before servicing; when changing accessories, such as blades, wheels, cutters, and like.

USE RECOMMENDED ACCESSORIES.

Consult the operating manual for recommended accessories. The use of improper accessories may cause risk of injury to persons.

CHECK DAMAGED PARTS. Before further use of the tool, a guard or other part that is damaged should be carefully checked to determine that it will operate properly and perform its intended function. Check for alignment of moving parts, binding of moving parts, breakage of parts, mounting, and any other conditions that may affect its operation. A guard or other part that is damaged should be properly repaired or replaced.

DO NOT EXCEED THE MAXIMUM MATERIAL SPECIFICATIONS.

DO NOT OPERATED UNIT WITHOUT GUARDS IN PLACE OR GUARDS NOT IN WORKING ORDER.

DO NOT PERFORM MAINTENANCE OR ADJUSTMENTS WITH POWER ON.

DO NOT PLACE FINGERS OR APPENDAGES IN OR NEAR OPENINGS IN GUARDS.

DO NOT RUN UNIT WITH INCORRECT LINE VOLTAGE. REFER TO LABEL PLACED OVER I/O SWITCH.

DO NOT ALLOW UNTRAINED OR UNQUALIFIED PERSONNEL TO OPERATE UNIT.

DO NOT DEFEAT ANY OF THE SAFETY FEATURES DESIGNED INTO THE UNIT.

IMPORTANT:

NO LIABILITY WILL BE INCURRED BY THE ERASER COMPANY FOR INJURY, DEATH, OR PROPERTY DAMAGE CAUSED BY A PRODUCT WHICH HAS BEEN SET UP, OPERATED, AND/OR INSTALLED CONTRARY TO ERASER'S WRITTEN OPERATING MANUAL, OR WHICH HAS BEEN SUBJECTED TO MISUSE, NEGLIGENCE, OR ACCIDENT, OR WHICH HAS BEEN REPAIRED OR ALTERED BY ANYONE OTHER THAN ERASER, OR WHICH HAS BEEN USED IN A MANNER OR FOR A PURPOSE FOR WHICH THE PRODUCT WAS NOT DESIGNED.

OPERATING INSTRUCTIONS

SET-UP:

The LFTC1 is supplied with one 3/32" Allen wrench, one 9/64" Allen wrench, & one 5/32" Allen wrench. Bushings must be purchased separately.

! CAUTION: The flexible tubing blade is intended for use on soft flexible. However, some rigid non-metallic tubing may be cut. The blade is a very thin sharp blade and caution should be used when handling it.

MODEL LFTC1 FLEXIBLE TUBE CUTTER

Place the Model LFTC1 on a sturdy workbench. Insert the external threaded end of the lengthstop rod into the threaded hole under the cutting head.

! CAUTION: BE SURE TO UNPLUG THE UNIT BEFORE PERFORMING ANY SET-UP OR MAINTENANCE.

BUSHING INSTALLATION:

To aid in bushing installation refer to picture 1 & 2. If different sizes of material are going to be cut, additional bushing sets must be ordered. There are two guide bushings, the entrance and exit bushing, loosen the 3/32" set screw with the Allen wrench provided. Install the entrance bushing so it is as close to the blade as possible.

! Caution: The blade must not come in contact with the bushing. Retighten the 3/32" set screw with the Allen wrench provided. Install the exit bushing in the front cover with the two screws provided.

ADJUSTING BLADE DEPTH:

Remove the plexiglass guard by removing the two screws near the top of the plexiglass plastic guard. Feed the tubing or cable into the entrance bushing up to the cutting blade. Loosen the blade depth adjusting screws (see picture 3) and adjust (rotating the adjusting screw counterclockwise will adjust the blade deeper) until the blade is completely through the wall of the tubing or just before touching the conductor in stripping applications. Retighten the blade locking screw once the blade is set to the correct depth. Cut quality will decrease if the blade is allowed to cut further than necessary to sever the tube. (Never allow the cutting blade to rotate further than the center of the guide).

The blade holder open stop screws should be set so that the material just clears when passed through. Secure with the locking screws. This will improve cut quality and decrease cycle time.

LENGTH STOP ADJUSTMENT:

Loosen the depth stop screw and adjust the length stop block to the desired cut/strip length and retighten it with the 5/32 Allen wrench. The cut length can be readjusted until the desired length is achieved. Longer cut lengths may be produced by purchasing additional length stop rods, (part #TR0176) which may be screwed directly into the

one provided with the machine. Reinstall the front guard. **See picture 4.**

OPERATION:

Connect the power cord to the IEC connector, and plug the unit into the appropriate power supply (either 115V 60Hz OR 230V 50Hz). Turn the machine on using the I/O switch on the top of the unit. Set the speed control to approximately 75% as a starting point. Push the material through the input bushing & exit bushing until it reaches the length stop block. See pictures 1 & 2. Press the foot pedal. This will activate the cutterhead to cut the material. When the material is cut, release the footswitch. The cut time will vary based on the material being cut. Cut times will range from a fraction of a second to several seconds. Lower machine speeds may cut better on smaller or softer materials & higher speeds will be necessary for thicker wall or harder materials. **See picture 2.**

SCORING WIRE OR CABLE:

The LFTC1 may be used for precision scoring of wire or cable jackets but may not be used for "slug" removal without damaging the machine. Eraser's Model LS10 Cable Stripper (part #AR0240) or Model LSA20 Cable Stripper (part #AR6800) will fulfill this need more productively than manual slug removal.

SET-UP FOR SCORING:

Install bushings per earlier procedure. Slide cable into the input bushing up to the blades. Adjust blades per blade adjustment but only to the conductor diameter. Set the blade stop screw for both blades. When running, be certain that the blades have completely retracted before removing product or damage to the product may result.

BLADE CHANGE OR REPLACEMENT:

NOTE: If this is the first time the blade has been dulled, it may be used again by turning the blade around and using the other side. The cutting edge of the blade is offset, so the blade may be used twice. **See picture 3.**

! CAUTION: Blades are very sharp. Be sure the unit is unplugged before changing blades.

To replace the cutting blade, remove the front cover with the 1/8" Allen wrench provided. Next, remove one of the screws holding the blade in place with the 5/32" Allen wrench provided and loosen the other one. Slide the blade out from under the screw.

MODEL LFTC1 FLEXIBLE TUBE CUTTER

Replace the blade and screw. Make certain that the blade is centered between both screws and slowly retighten them. Confirm that blade is not bowed.

See picture 3.

Check the blades for wear after prolonged use.

See picture 3.

BELT TENSIONING OR REPLACEMENT:

Belt tensioning or replacement is accomplished by removing the 4 screws on the rear housing with a #2 Phillips screwdriver. Remove rear housing. Be careful not to disconnect wiring. Remove the 2 screws on the plexiglass guard with a 1/8" Allen wrench and remove the plexiglass guard. Loosen the 4 motor mounting screws using the 5/32" Allen wrench. Slip the old belt off the cutterhead pulley and the motor pulley and replace with the new one - while facing the plexiglass guard. Slide the motor to the right & hold in place while tightening the 4 mounting screws. Replace the rear housing and plexiglass guard, reinstall hardware. Reapply power and start the machine. If the belt slips on startup, disconnect power supply and repeat the process but apply more tension to the belt before tightening the motor mounting screws. **See pictures 1, 2, & 4.**

No other maintenance is required for the units.

TROUBLESHOOTING

PROBLEM:

The blade does not move and is stuck in a closed position.

SOLUTION:

Adjust the blade as described in the blade change or replacement section.

PROBLEM:

Poor quality cut or no cut.

SOLUTIONS:

- 1) Check that the blade is not dull. Rotate or replace if necessary. See the "Blade Change or Replacement Section".
- 2) Check blade depth adjustment.

PICTURE 1

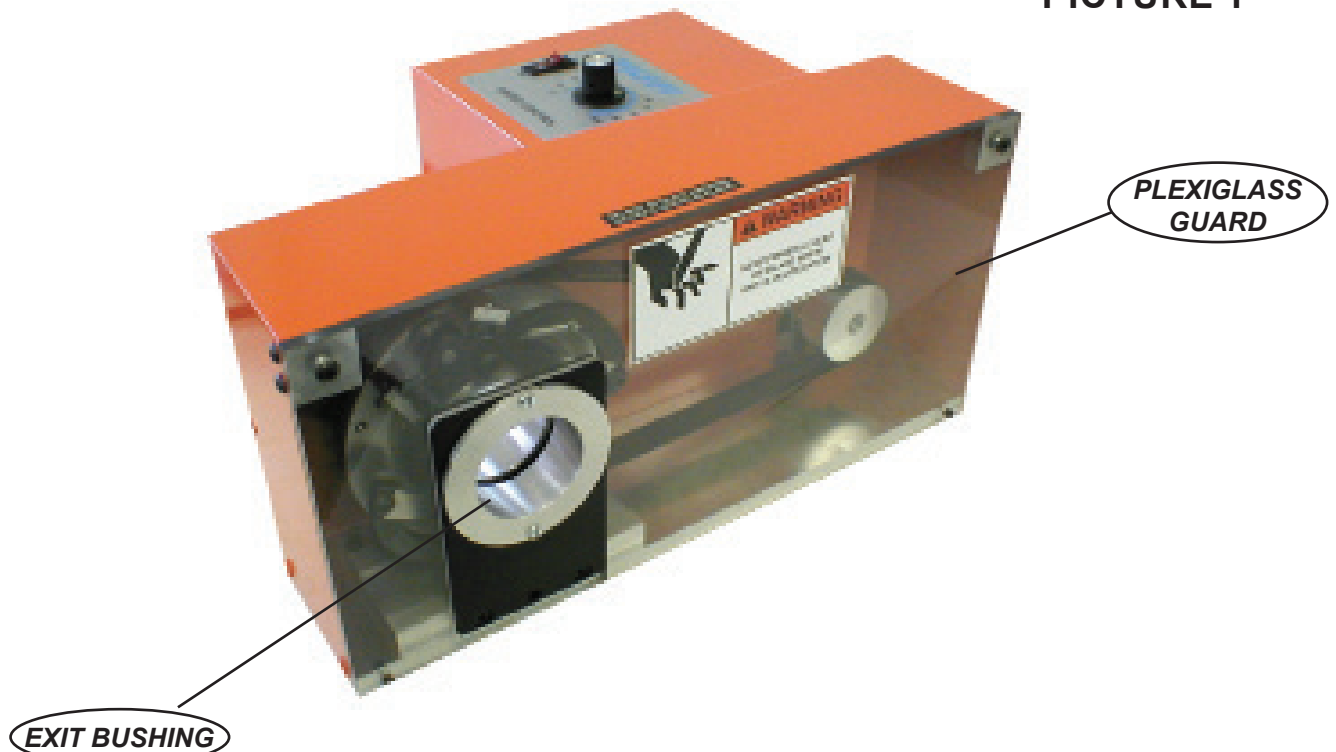

MODEL LFTC1 FLEXIBLE TUBE CUTTER

PICTURE 2

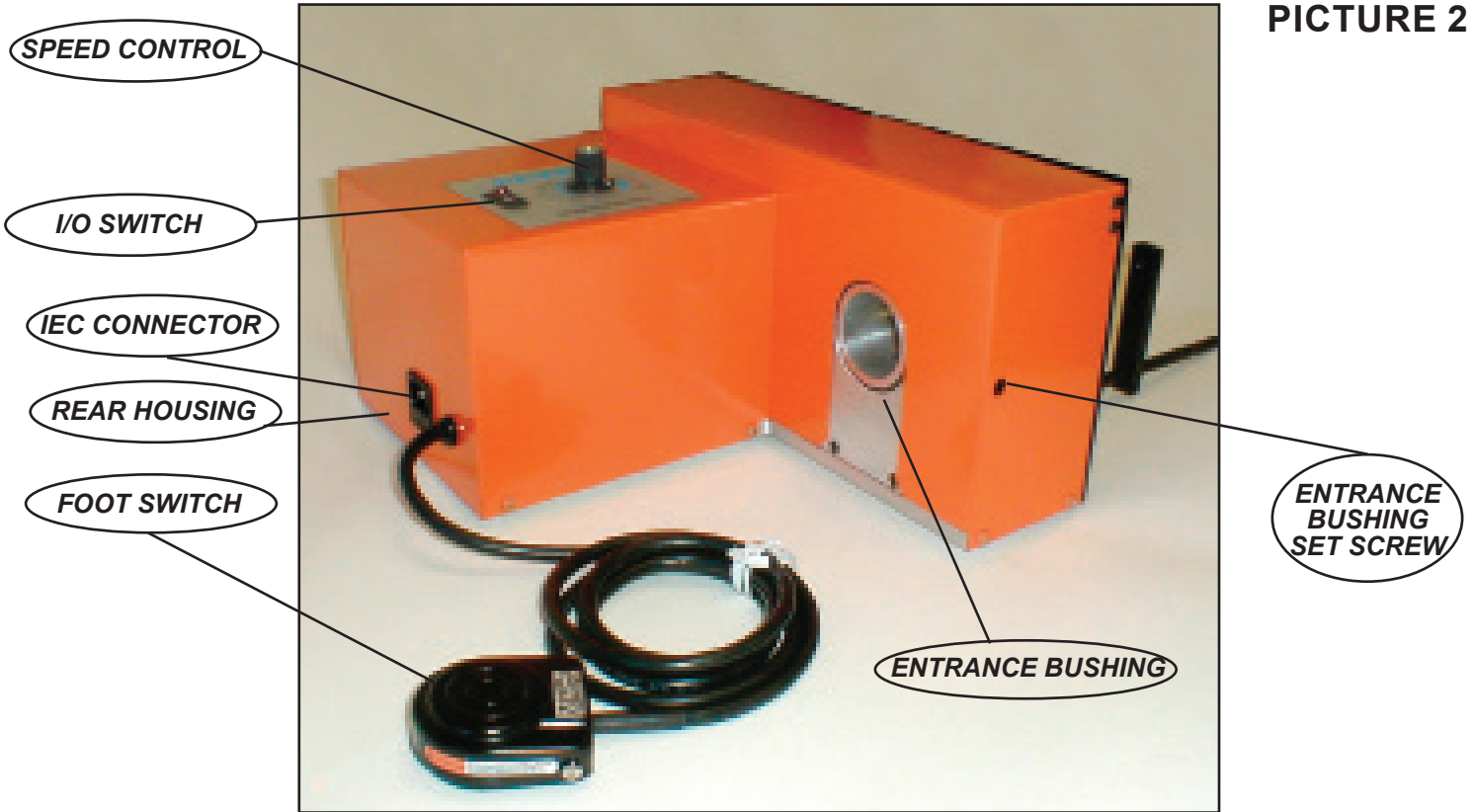

PICTURE 3

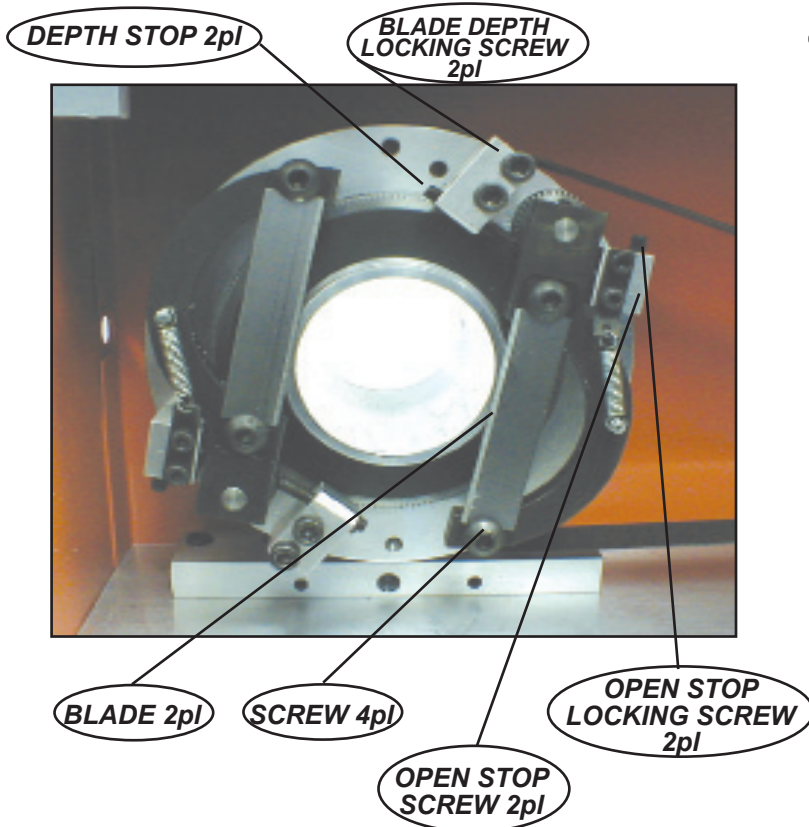

PICTURE 4

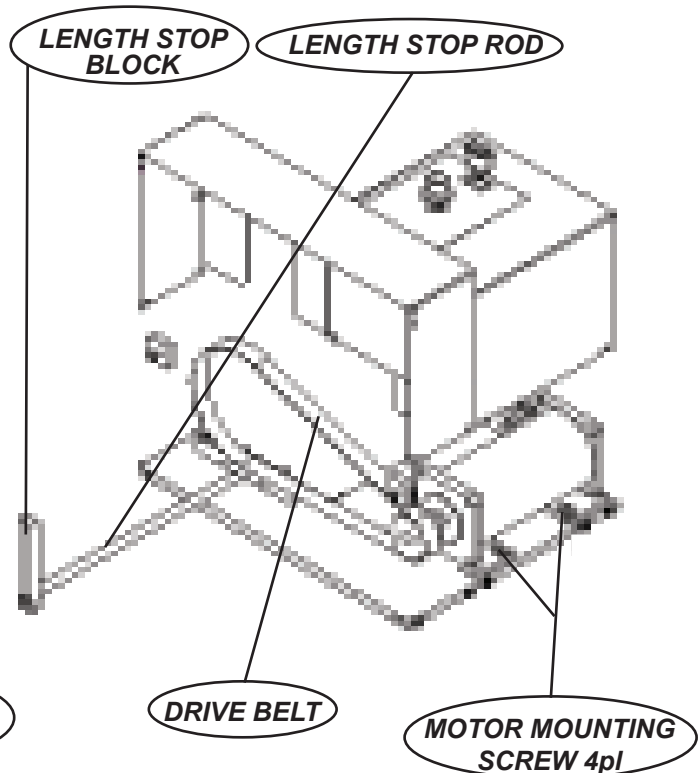

MODEL LFTC1 FLEXIBLE TUBE CUTTER

p 7

NOTES:

The Eraser Company, Inc.
PO Box 4961
Syracuse, NY 13221, USA



Phone: (315) 454-3237
Fax: (315) 454-3090
Website: www.eraser.com
E-mail: info@eraser.com

IR1822
REV 09/21